

SIZE D	DRAWING	SHT. OF	REV.	PROPRIETARY INFORMATION
-----------	---------	------------	------	-------------------------

QTY.	PART NUMBER	ITEM DESCRIPTION	ITEM
------	-------------	------------------	------

Power Inlet
on top, left rear corner of machine

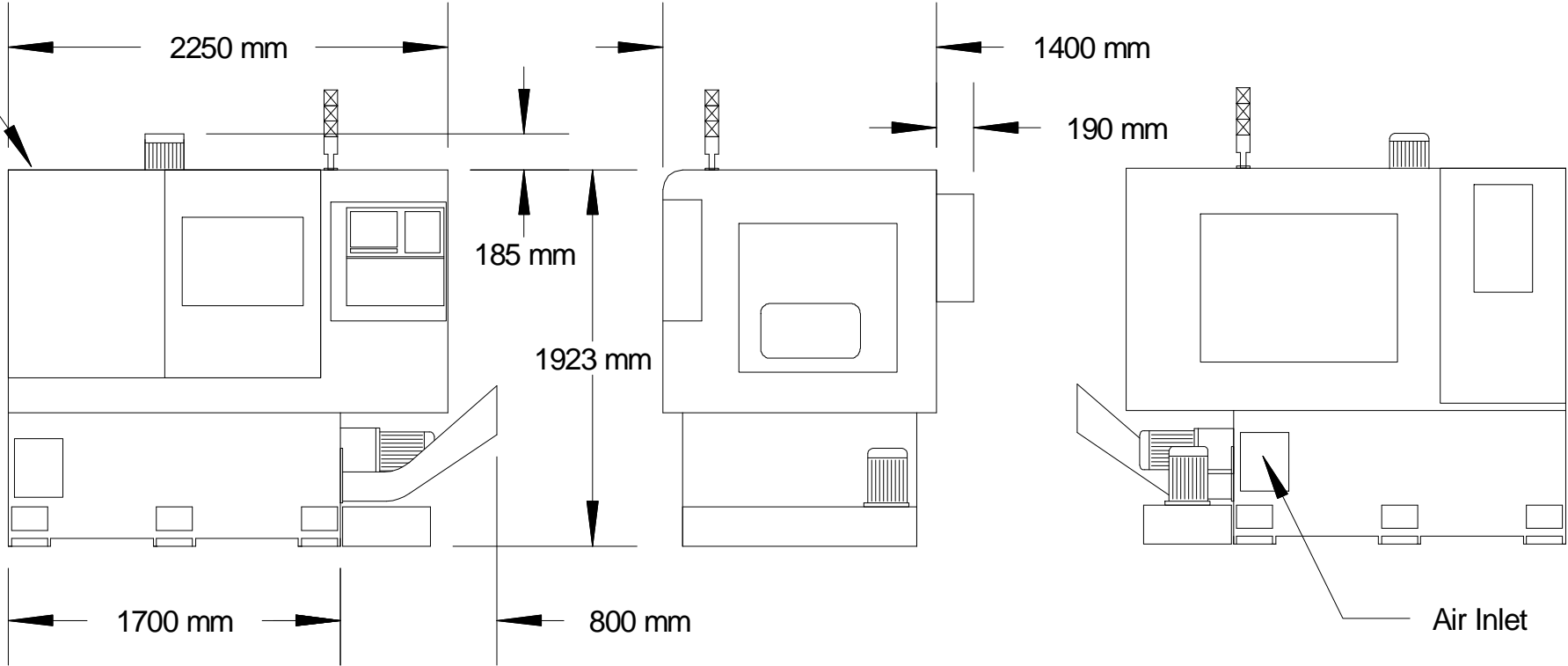

REV	E.C.N. NO.	REVISION DESCRIPTION	REV BY	DATE	CHK BY	DATE	APP BY	DATE	DF

SURFACE TREATMENT	EXCEPT AS NOTED: ALL CORNERS MUST BE AS FOLLOWS INSIDE: .050" X 45° OR .05" R MAX OUTSIDE: .030" X 45° OR .05" R	EXCEPT AS NOTED: ALL DIMENSIONS IN INCHES TOLERANCE DECIMAL .0 ±.0300 .00 ±.0180 .000 ±.0050 .0000 ±.0005 ANGULAR ± 0°30'
HEAT TREATMENT		
FIRST USED ON	EXCEPT AS NOTED: WELDING TOLERANCE MUST BE AS FOLLOWS ±.12	THIRD ANGLE PROJECTION

GANESH					
DESCRIPTION CYCLONE 32 Sub spindle					
DRAWN	DATE	CHECKED	DATE	APPROVED	DATE
SCALE N/A	SIZE D	DRAWING	SHT. OF	REV.	
UNIT OF MEAS. EA					

SIZE D	DRAWING	SHT. OF	REV.	PROPRIETARY INFORMATION	QTY.	PART NUMBER	ITEM DESCRIPTION	ITEM
-----------	---------	------------	------	-------------------------	------	-------------	------------------	------

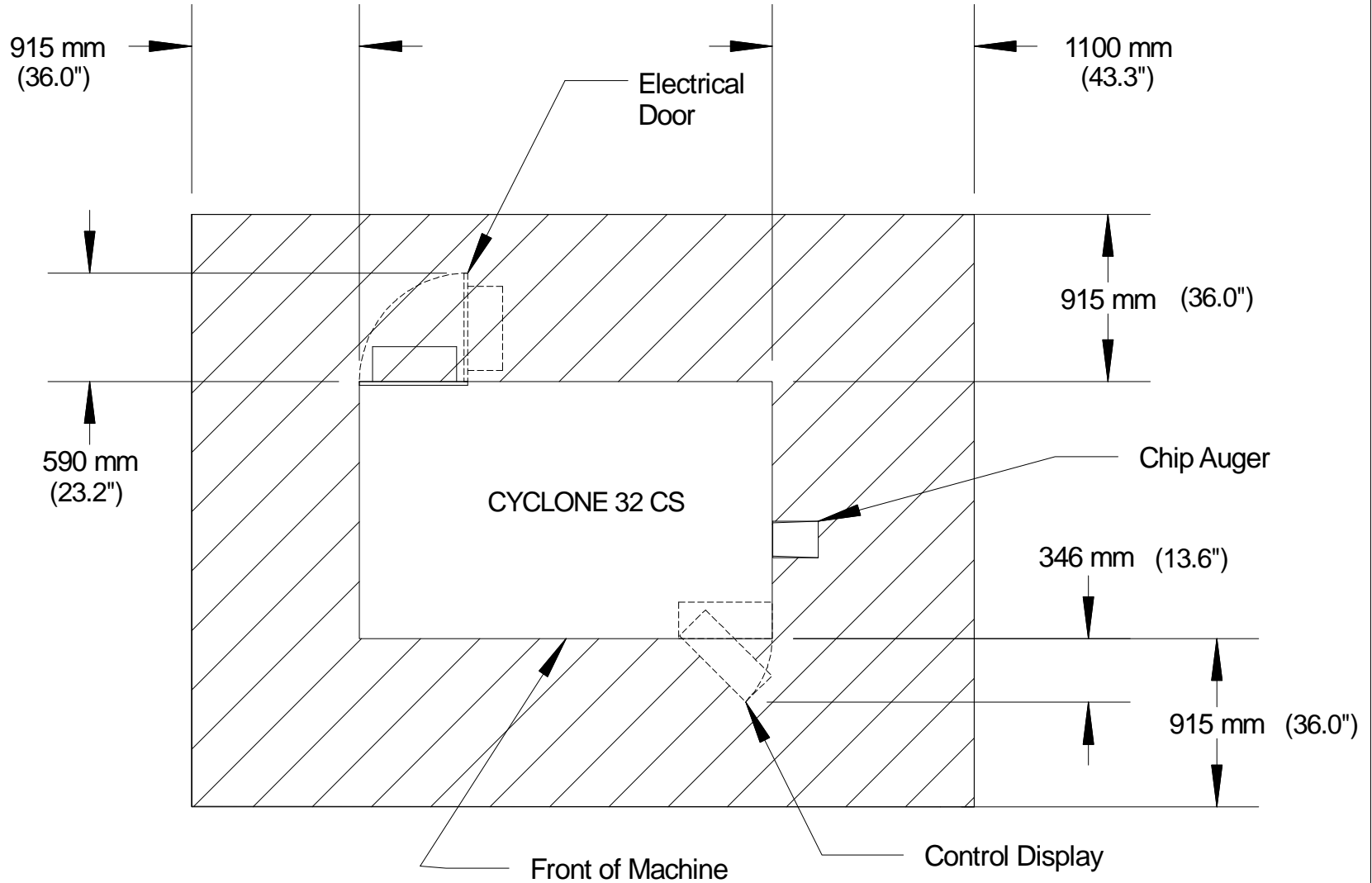

REV	E.C.N. NO.	REVISION DESCRIPTION	REV BY	DATE	CHK BY	DATE	APP BY	DATE	DF

SURFACE TREATMENT	EXCEPT AS NOTED: ALL CORNERS MUST BE AS FOLLOWS INSIDE: .050" X 45° OR .05" R MAX OUTSIDE: .030" X 45° OR .05" R	EXCEPT AS NOTED: ALL DIMENSIONS IN INCHES TOLERANCE DECIMAL .0 ±.0300 .00 ±.0180 .000 ±.0050 .0000 ±.0005 ANGULAR ± 0°30'
HEAT TREATMENT		
FIRST USED ON	EXCEPT AS NOTED: WELDING TOLERANCE MUST BE AS FOLLOWS ±.12	THIRD ANGLE PROJECTION

GANESH

DESCRIPTION
CYCLONE 32 Sub spindle

DRAWN	DATE	CHECKED	DATE	APPROVED	DATE

SCALE: N/A
UNIT OF MEAS: EA

SIZE: D

SHT.	REV.